



The University of
Nottingham



e-Portfolio Reference Model Domain maps of HE Admissions

Peter Rees Jones JISC-CETIS

**Dr Angela Smallwood Director The
International Centre for e-Portfolio
Development**

Sandra Kingston Project Manager

Domain maps of HE Admissions

- The reference model has mapped the HE admissions process, concentrating on a Personal Profiling Service but scoping out Advice and Guidance; Feedback and Personal Planning Services
- We will tell the generic story of how a learner makes an application and is inducted into HE
- And then the specific story of how a learner who left college early applies through a LifeLong Learning Network

Standard Pattern: Apply to HE Use Case

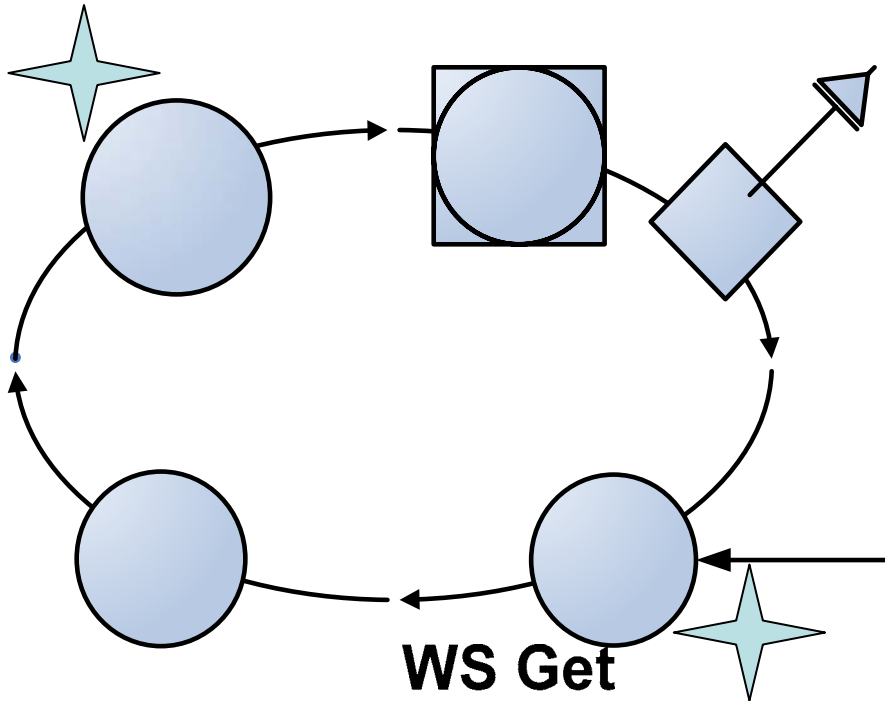

WS Get
e-P item

We have commissioned 2
prototype web services

A set of web services help me develop a profile of myself in terms of the course entry profile setting out the requirements for a particular HEI. I discuss the profile with my advisor.

Assessment
OR
Reference

Comments
(IAG stands for Information, Advice and Guidance)

Decision

The Personal Statement Service Loop Pattern

Standard Pattern: Apply to HE Use Case

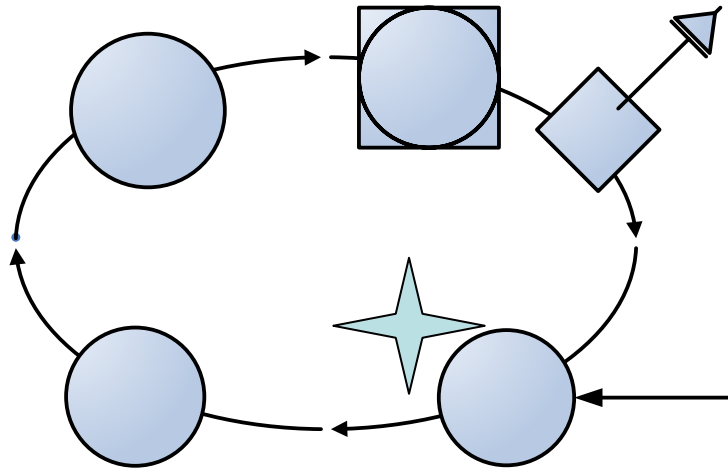

The entry profile is called into a template for a structured personal statement

(IAG)
Assessment

Either
Progress to
Application

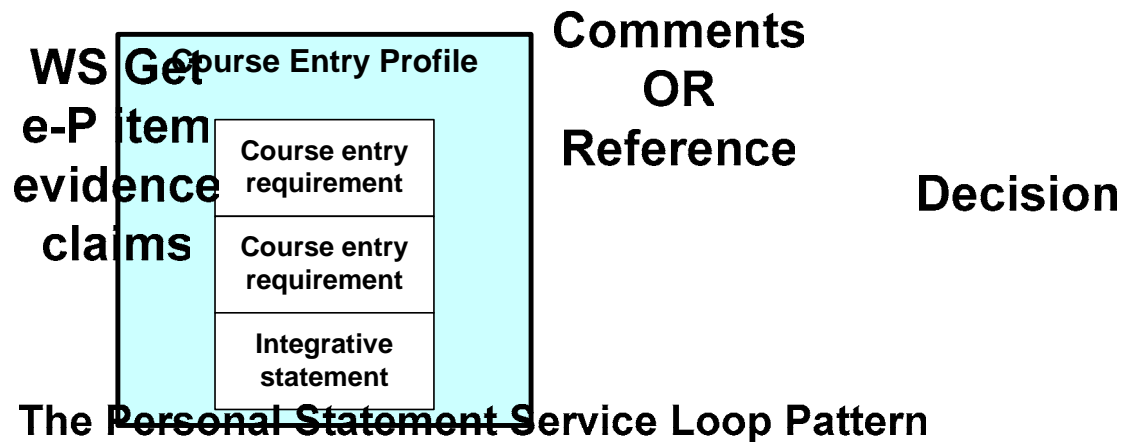

The Personal Statement Service Loop Pattern

Standard Pattern: Apply to HE Use Case

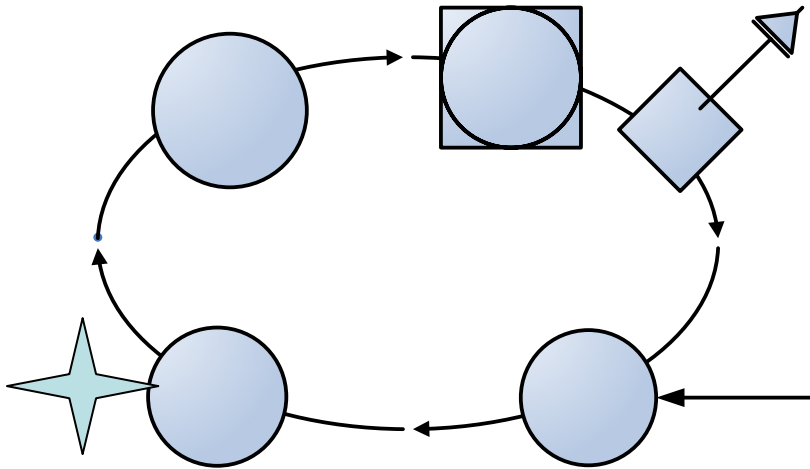

I draw on my e-Portfolio to create a profile

(IAG)

Assessment

Either
Progress to
Application

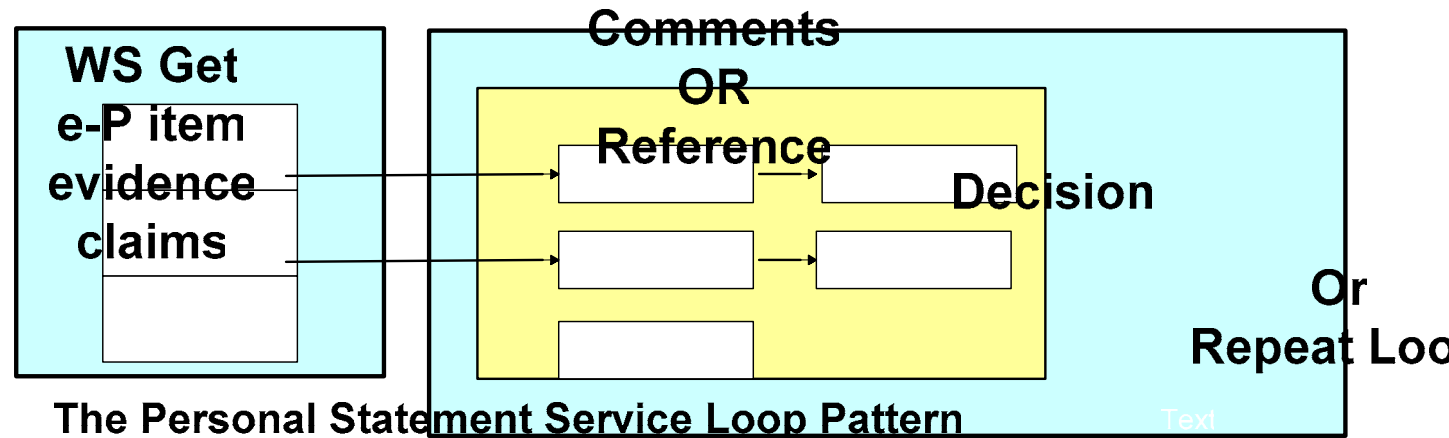

Standard Pattern: Apply to HE Use Case

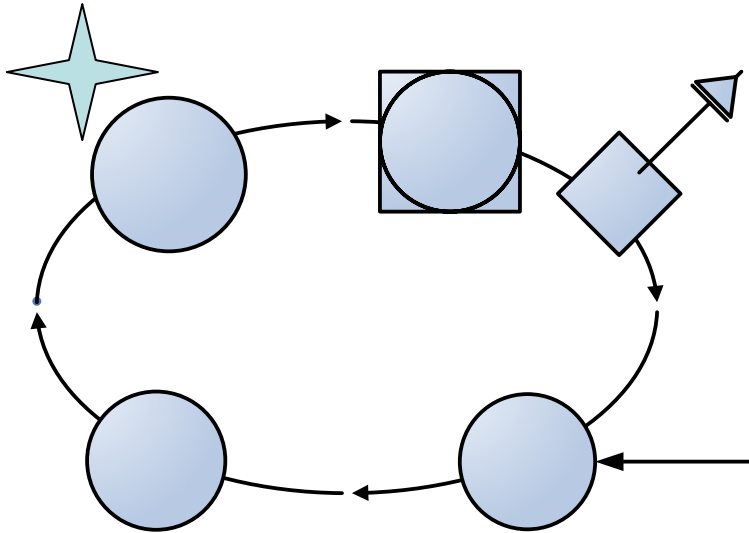

Either
 A web service helps me progress to
 assertions and activities to Application
 evidence in my eP

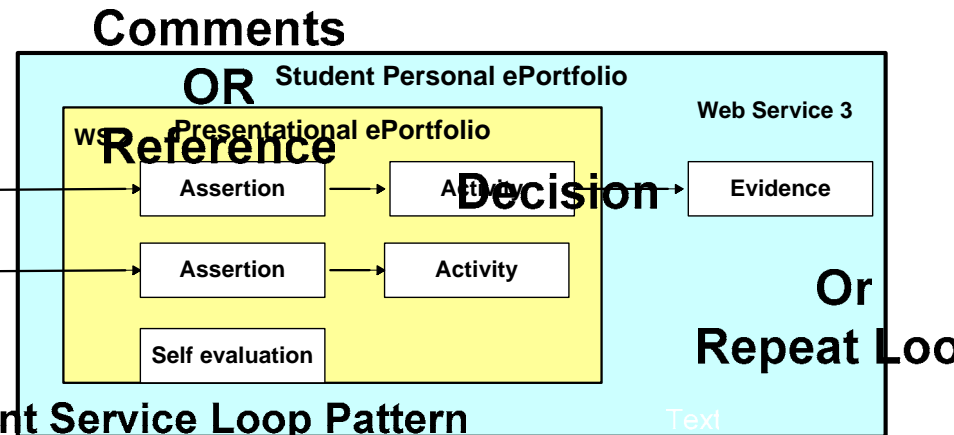
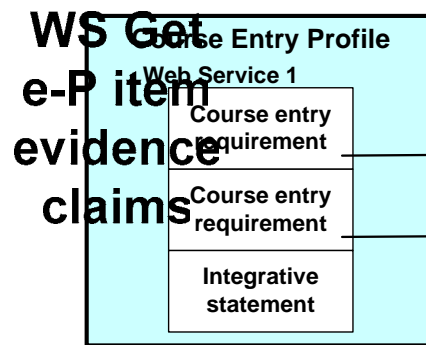

The Personal Statement Service Loop Pattern

Standard Pattern: Apply to HE Use Case

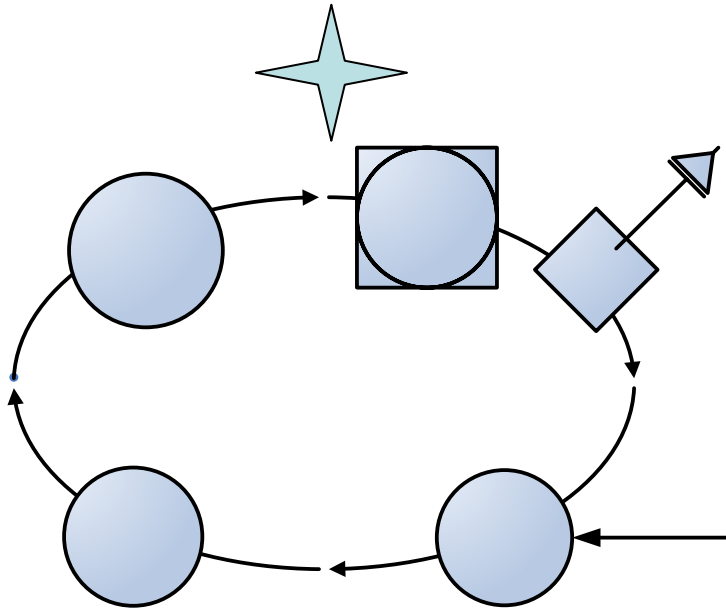

A WS helps my adviser to formatively assess the statement AND ALSO allows my referee to make a summative assessment of the statement.

Either progress to Application Assessment

This pattern has a strong association with diagnostic, formative & summative assessment

WS Get evidence claims

The Personal Statement Service Loop Pattern

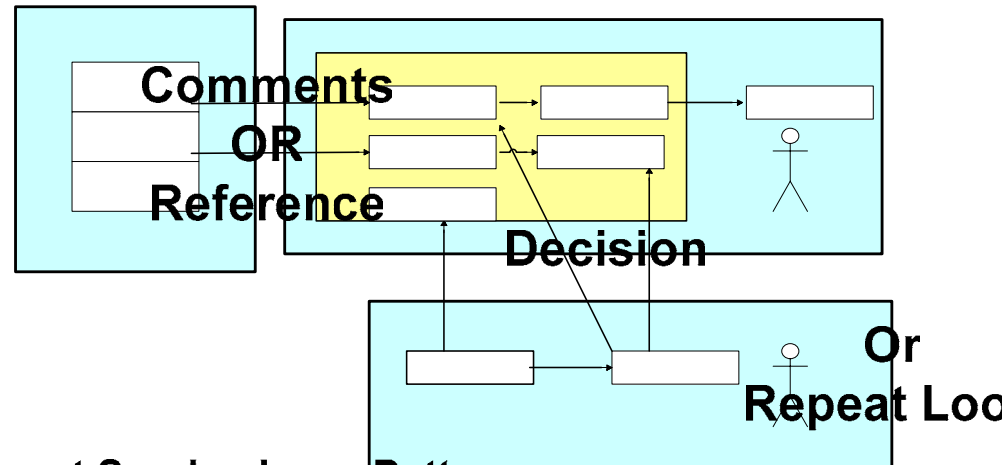

First iteration: context for the use case

This *Profiling Service* enables me to develop a profile of myself in terms of the profile of an opportunity, such as an HE course or a job.

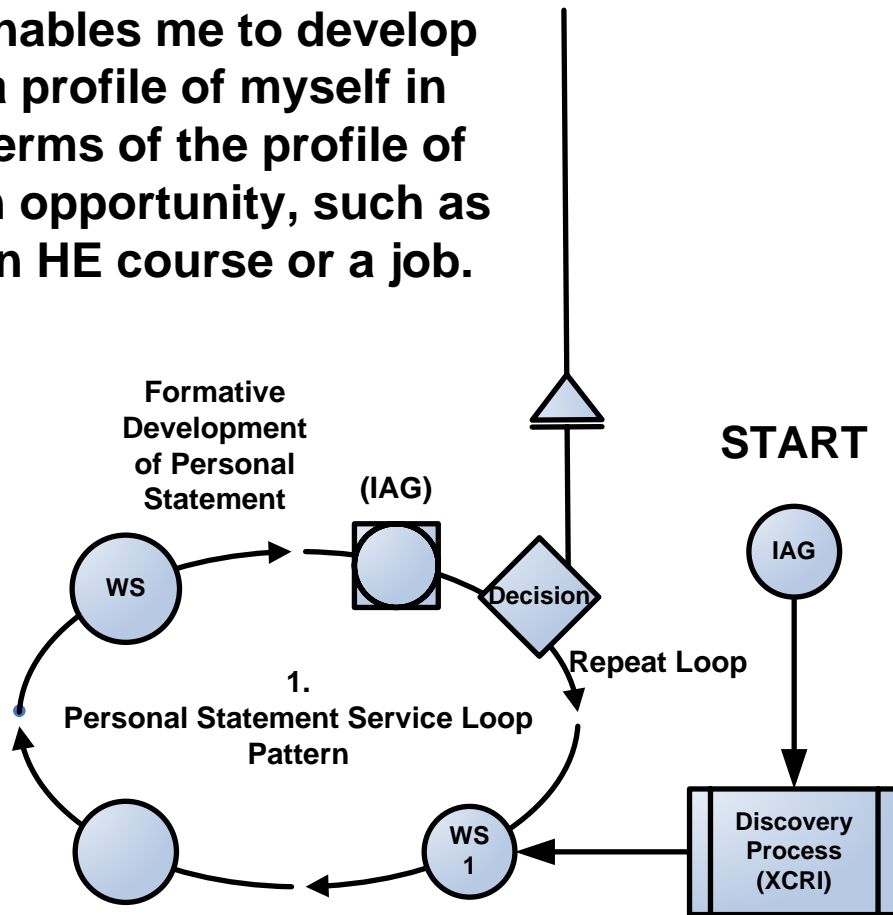

Typically the trigger for the initial use case is an Information Advice and Guidance (IAG) session with an advisor, prompting the potential applicant to use a *Discovery Service*: Having identified some possibilities I use the *Profiling Service*. The loop may be completed many times until I wish to make a formal application

2nd iteration: feedback & induction

There is an outline spec of web services for a centralised admissions process that can produce feedback.

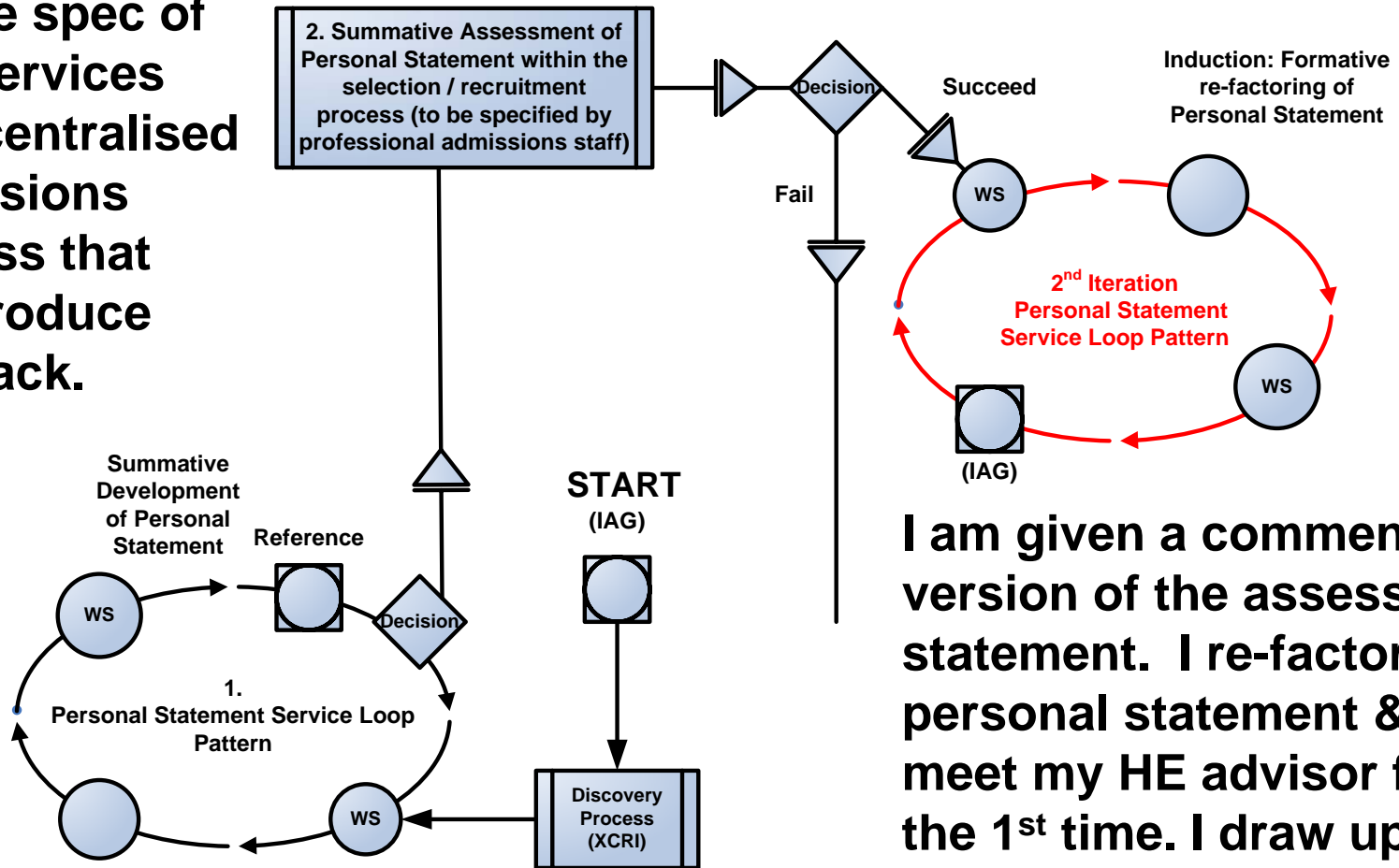

I am given a commented version of the assessed statement. I re-factor my personal statement & meet my HE advisor for the 1st time. I draw up an action plan for my HE use of e-Portfolio.

Third iteration

Abstract Model of a Personal Statement Service

Unsuccessful applicants receive the same feedback that they review before meeting their advisor.

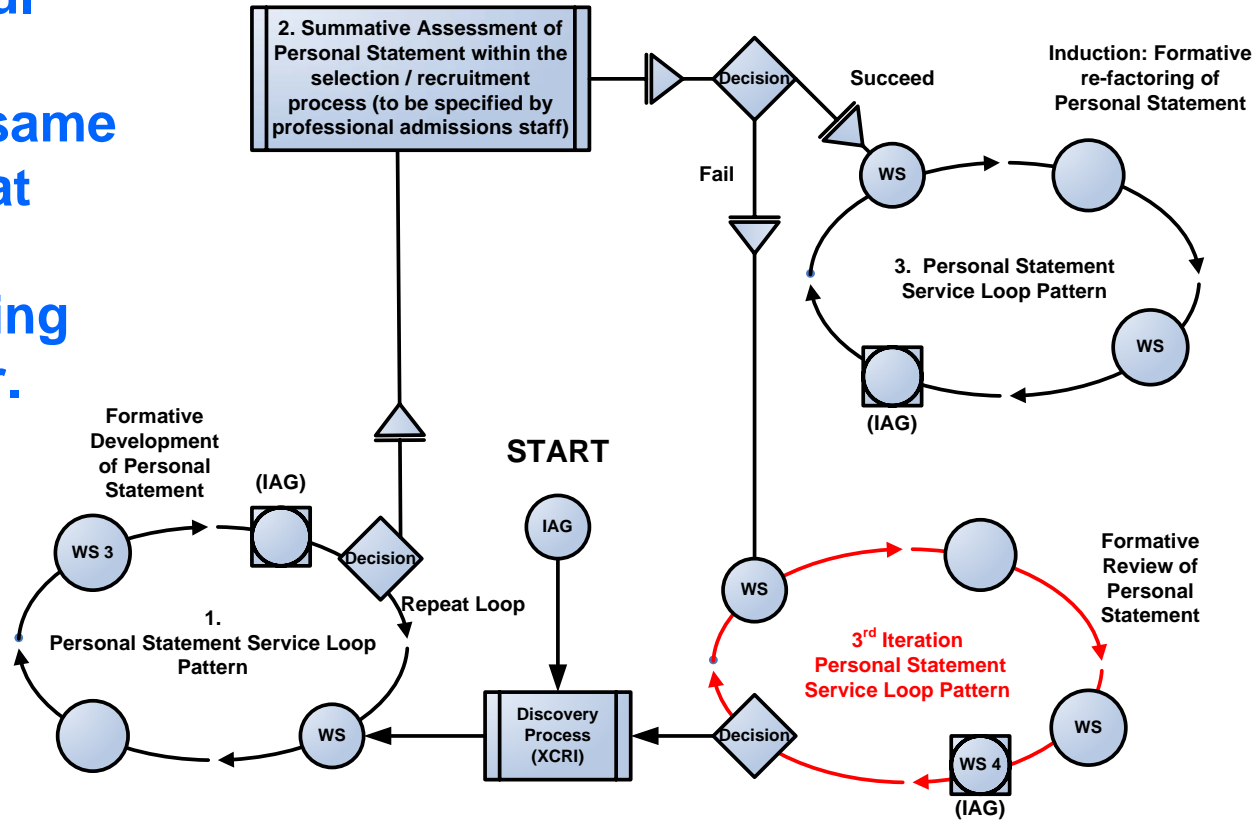

Regional Perspective

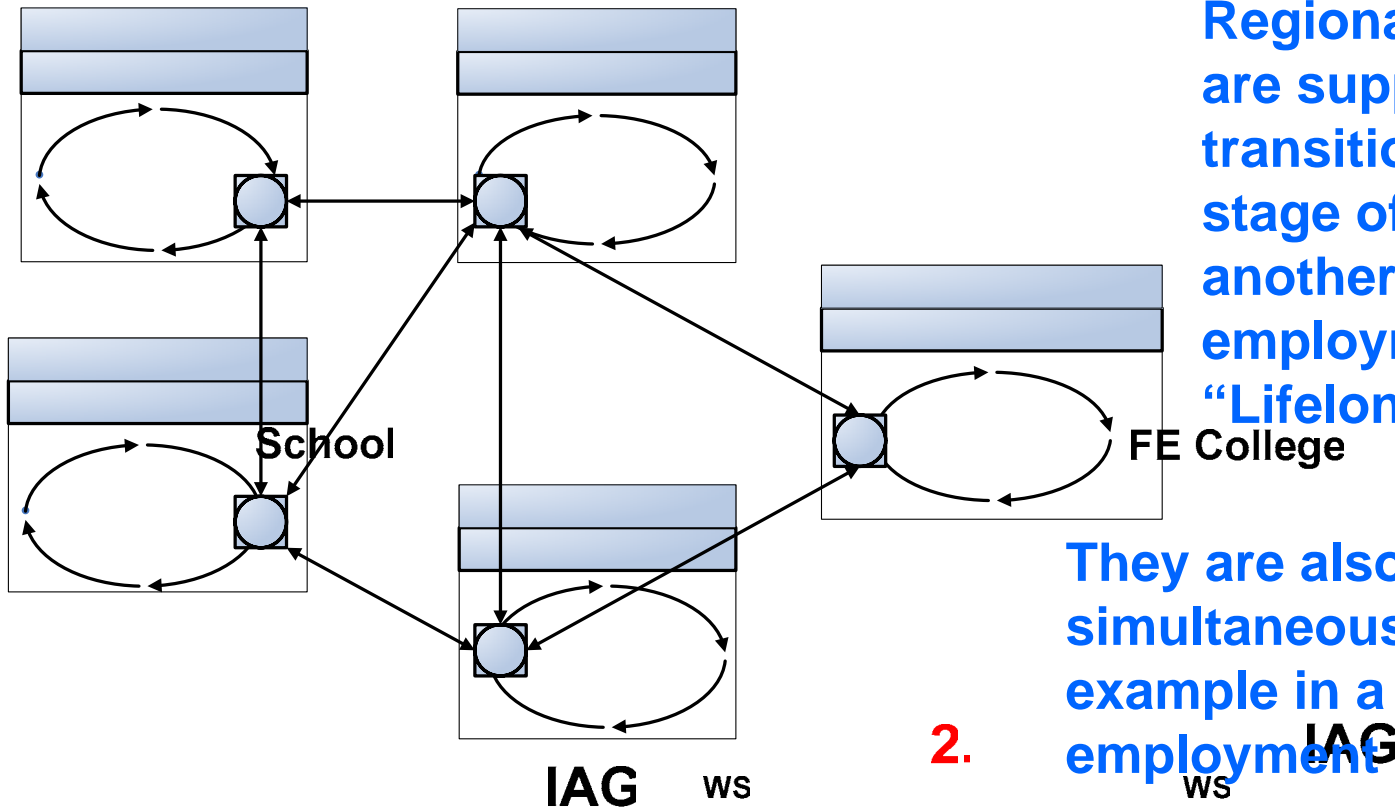

How may the process of applying to HE look to me if I left college aged 17, have worked for a couple of years but now want to apply?

1.

3.

5.

Training Provider

Regional Partnership Service Flow

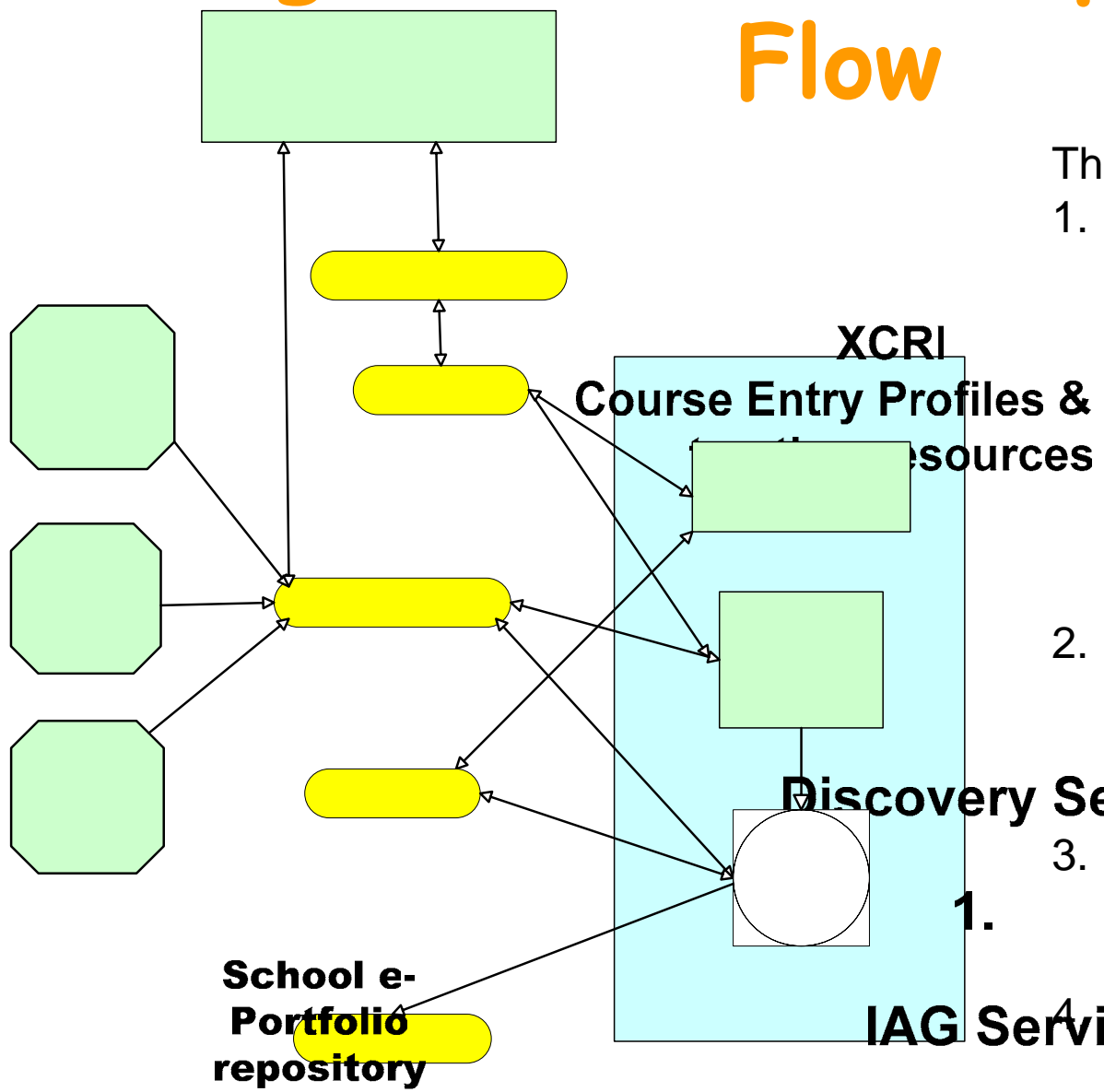

The Use Case:

1. My union Rep tells me that the LLN can help me apply to HE. I meet an advisor who shows me how to use the Partnership e-Portfolio: we discover a suitable course and download the application form.
2. I use the Profiling Service to recover information from my old portfolios and complete my application
3. My advisor and I chat online on how I can improve the application.
4. I apply!

LLN Part
ePort

Regional Partnership Service Flow

- Deliverable 1.** A set of outline domain maps for HE application for new JISC projects to take forward in 2007
- Deliverable 2.** A re-factoring of these service flows for regional partnerships to take forward with an emphasis on integrative learning
- Deliverable 3.** A thin model of e-Portfolio in terms of the e-Framework as a basis for future development in the UK and with international partners.